

Threads

CSCI 315 Operating Systems Design
Department of Computer Science

Notice: The slides for this lecture have been largely based on those accompanying the textbook *Operating Systems Concepts*, 9th ed., by Silberschatz, Galvin, and Gagne, Prof. Xiannong Meng's slides, and Blaise Barney (LLNL) "POSIX Threads Programming" online tutorial.



Interlude

Pointer Recap

NAME

`wait, waitpid, waitid` - wait for process to change state

SYNOPSIS

```
#include <sys/types.h>
```

```
#include <sys/wait.h>
```

```
pid_t wait(int *status);
```

```
pid_t waitpid(pid_t pid, int *status, int options);
```

Pointer Recap

```
int ret_val;  
.  
.  
.  
ret_val = wait( -???- );  
.  
.  
.
```

Pointer Recap

```
int ret_val;  
int *status;  
.  
.  
.  
ret_val = wait(status);  
.  
.  
.
```

```
int ret_val;  
int status;  
.  
.  
.  
ret_val = wait(&status);  
.  
.  
.
```

- Do both options **compile** correctly?
- Do both options **run** correctly?
- Can you explain what each one does?

Pointer Recap 2

```
char *c;  
.  
.  
.  
*c = 'a';  
.  
.  
.
```

- Do this **compile** correctly?
- Do this **run** correctly?

Pointer Recap 2

```
char *c;  
.  
.  
.  
*c = 'a';  
.  
.  
.
```

```
char *c = malloc(10);  
.  
.  
.  
*c = 'a';  
.  
.  
.
```

What is the difference between the two?

Pointer Recap 2

```
char *c = malloc(10);  
.  
.  
.  
*c = 'a';  
.  
.  
.
```

```
char *c = malloc(10);  
.  
.  
.  
*c = 'a';  
c[1] = c[0];  
*(c+2) = c[1];  
.  
.
```

- What is the value of `c[1]` after the assignment?
- What is the value of `c[2]` after the assignment?

Function Recap

```
int summation(int start, int end);
```

Function Recap

Function prototype

```
int summation(int start, int end)
```

data
type of
return
value

function
name

formal
arguments

Function Recap

Function prototype

```
int summation(int start, int end);
```

What is this???

```
int *f(int, int);
```

Function Pointer Recap

Function prototype

```
int summation(int start, int end);
```

Function pointer declaration

```
int *f(int, int);
```

Function pointer assignment

```
f = summation;
```

Function Pointer Parameter

Function prototype

```
int compute(int, int, int *g(int, int));
```

Function body

```
int compute(int a, int b, int *g(int, int) {  
    return g(a, b);  
}
```

Function Recap

Function prototype

```
int summation(int start, int end)
```

data
type of
return
value

function
name

formal
arguments

And now, our main attraction...

Motivation

- Process level concurrency is often not enough.
- One **process** may contain multiple **threads**.
- Many modern applications are multithreaded.
- **Different tasks** within the application can be implemented by **different threads**: update display, fetch data, check spelling, service a network request.
- Process creation is time consuming, thread creation is not.
- Threads can simplify coding and increase efficiency.
- OS Kernels are generally multithreaded. OS and/or libraries have support for user-level threads.

More Motivation?

- **Responsiveness:** multiple threads can be executed in parallel (in multi-core machines)
- **Resource sharing:** multiple threads have access to the same data, sharing made easier
- **Economy:** the overhead in creating and managing threads is smaller
- **Scalability:** more processors (or cores), more threads running in parallel

Applications: A Hierarchical View

computer

programs

processes

threads

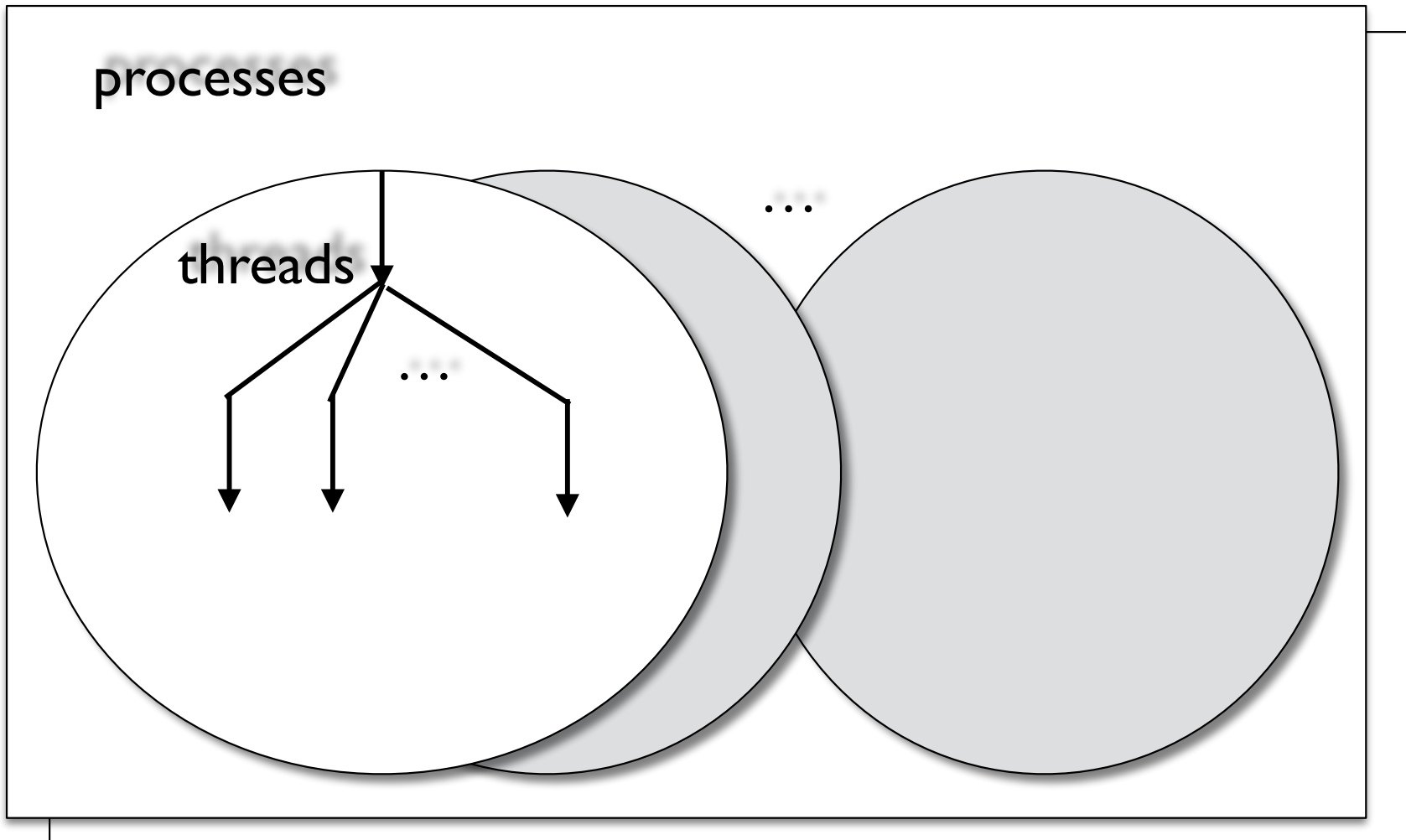

Concurrency and Parallelism

Concurrent execution in single-core system

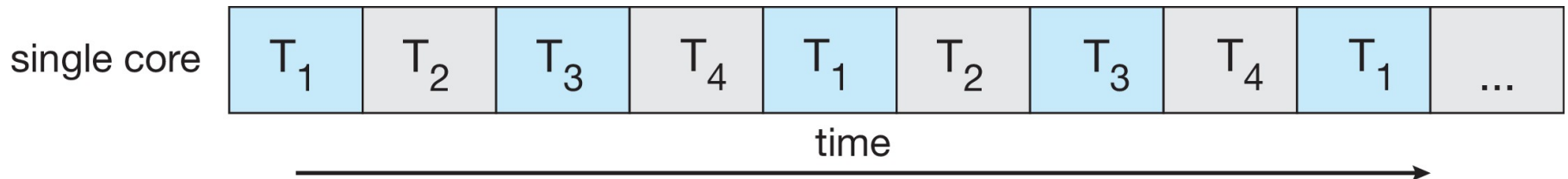

Parallelism on multi-core system

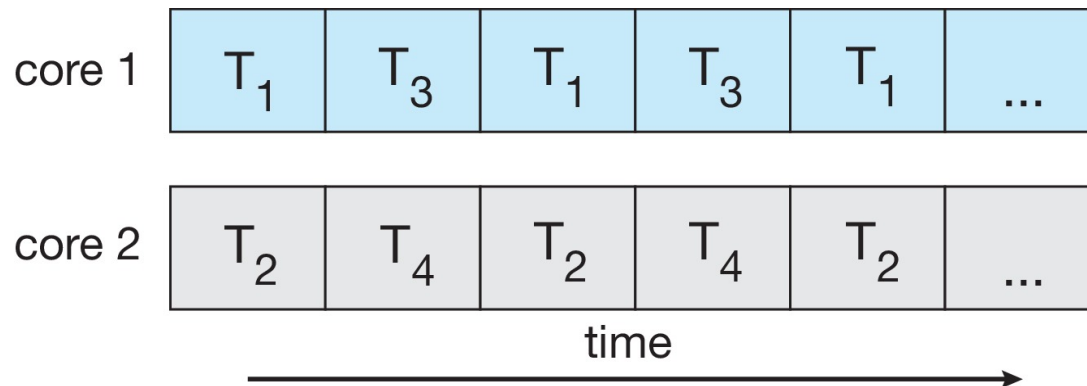

Look at `pthread_create(3)`

NAME

`pthread_create` - create a new thread

SYNOPSIS

```
#include <pthread.h>
```

```
int pthread_create(pthread_t *thread,  
                  const pthread_attr_t *attr,  
                  void *(*start_routine) (void *),  
                  void *arg);
```

Compile and link with `-pthread`.

Explain:

(a) what `void *p;` means

(b) what this means: `void *(*start_routine) (void *)`

Here's the code for my thread:

```
void *sleeping(void *arg) {
    int sleep_time = (int)arg;
    printf("thread %ld sleeping %d seconds ...\\n",
        pthread_self(), sleep_time);
    sleep(sleep_time);
    printf("\\nthread %ld awakening\\n", pthread_self());
    return (NULL);
}
```

OK, how do I understand this?

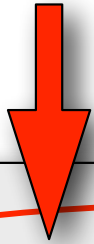

```
void *sleeping(void *arg) {  
    int sleep_time = (int)arg;  
    printf("thread %ld sleeping %d seconds ...\n",  
        pthread_self(), sleep_time);  
    sleep(sleep_time);  
    printf("\nthread %ld awakening\n", pthread_self());  
    return (NULL);  
}
```

Creating five identical threads

```
/* COMPILE WITH: gcc thread-ex.c -lpthread -o thread-ex */
#include <stdio.h>
#include <pthread.h>
#define NUM_THREADS 5
#define SLEEP_TIME 3

void *sleeping(void *); /* forward declaration to thread routine */

int main(int argc, char *argv[]) {
    int i;
    pthread_t tid[NUM_THREADS]; /* array of thread IDs */
    for ( i = 0; i < NUM_THREADS; i++)
        pthread_create(&tid[i], NULL, sleeping, (void *)SLEEP_TIME);

    for ( i = 0; i < NUM_THREADS; i++)
        pthread_join(tid[i], NULL);

    printf("main() reporting that all %d threads have terminated\n", i);
    return (0);
} /* main */
```

So, threads can't take parameters and can't return anything?

```
void * sleeping(void *arg) {
    int sleep_time = (int)arg;
    printf("thread %ld sleeping %d seconds ...\n",
        pthread_self(), sleep_time);
    sleep(sleep_time);
    printf("\nthread %ld awakening\n", pthread_self());
    return (NULL);
}
```

A thread can take parameter(s) pointed by its **arg** and can return a pointer to some memory location that stores its results. Gotta be careful with these pointers!!!

Passing arguments into thread

```
pthread_t tid[NUM_THREADS]; /* array of thread IDs */
for ( i = 0; i < NUM_THREADS; i++)
    pthread_create(&tid[i], NULL, sleeping, (void *)SLEEP_TIME);
...
```

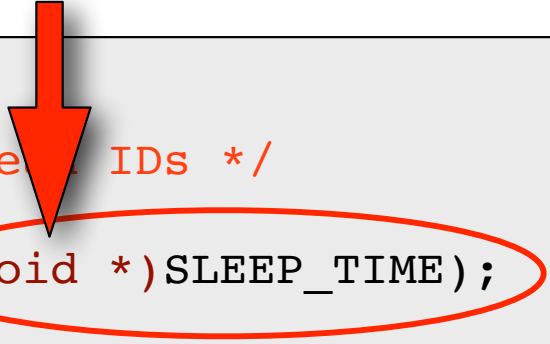

- Casting is powerful, so it deserves to be used carefully
- This is disguising an integer as a `void *` **(a hack?)**
- Have to remove the disguise inside the thread routine

Passing arguments into thread

```
struct args_t {
    int id;
    char *str;
} myargs[NUM_THREADS];

void * thingie(void *arg) {
    struct args_t *p = (struct args_t*) arg;
    printf("thread id= %d, message= %s\n", p->id, p->msg);
}
```

```
for ( i = 0; i < NUM_THREADS; i++)
    pthread_create(&tid[i], NULL, thingie, (void *)&myargs[i]);

...
```

Passing results out of thread

```
struct args_t {
    int id;
    char *str;
    double result;
} myargs[NUM_THREADS];

void * thingie(void *arg) {
    struct args_t *p = (struct args_t*) arg;
    printf("thread id= %d, message= %s\n", p->id, p->msg);
    p->result = 3.1415926 * p->id;
    return(NULL); // or return(arg)
}
```

Option 1

Passing results out of thread

```
struct args_t {  
    int id;  
    char *str;  
} myargs[NUM_THREADS];
```

```
struct results_t {  
    double result;  
};
```

```
void * thingie(void *arg) {  
    struct args_t *p = (struct args_t*) arg;  
    struct results_t *r = malloc(sizeof(struct results_t));  
  
    printf("thread id= %d, message= %s\n", p->id, p->msg);  
    r->result = 3.1415926 * arg->id;  
    return((void*) r);  
}
```

Watch out for
memory leaks!

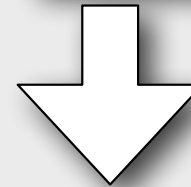

Option 2

Your thread returns a `void *`

What is the point of returning this value?

Look at `pthread_join(3)`

NAME

`pthread_join` - join with a terminated thread

SYNOPSIS

```
#include <pthread.h>
```

```
int pthread_join(pthread_t thread, void **retval);
```

Analogous to `wait(2)` and `waitpid(2)`

```
pid_t wait(int *status);  
pid_t waitpid(pid_t pid, int *status, int options);
```

Look at pthread_join(3)

NAME

pthread_join - join with a terminated thread

SYNOPSIS

```
#include <pthread.h>
```

```
int pthread_join(pthread_t thread, void **retval);
```



A pointer to a pointer to something

Threads and Processes

Process

Process ID,
process group ID,
user ID, group ID,
Environment,
Program instructions,
Registers,
Stack,
Heap,
File descriptors,
Signal actions,
Shared libraries,
IPC message queues, pipes,
semaphores, or shared
memory).

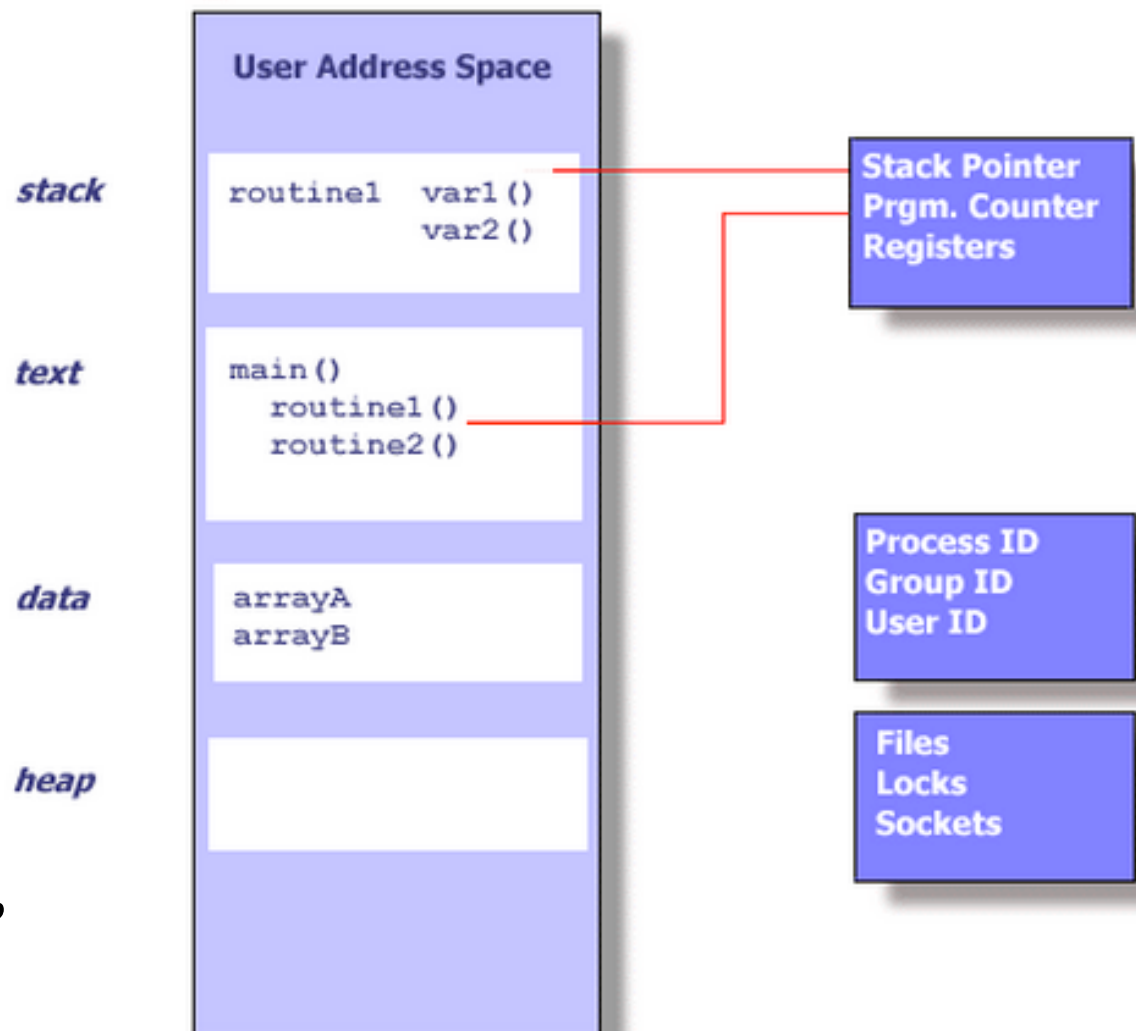

Thread

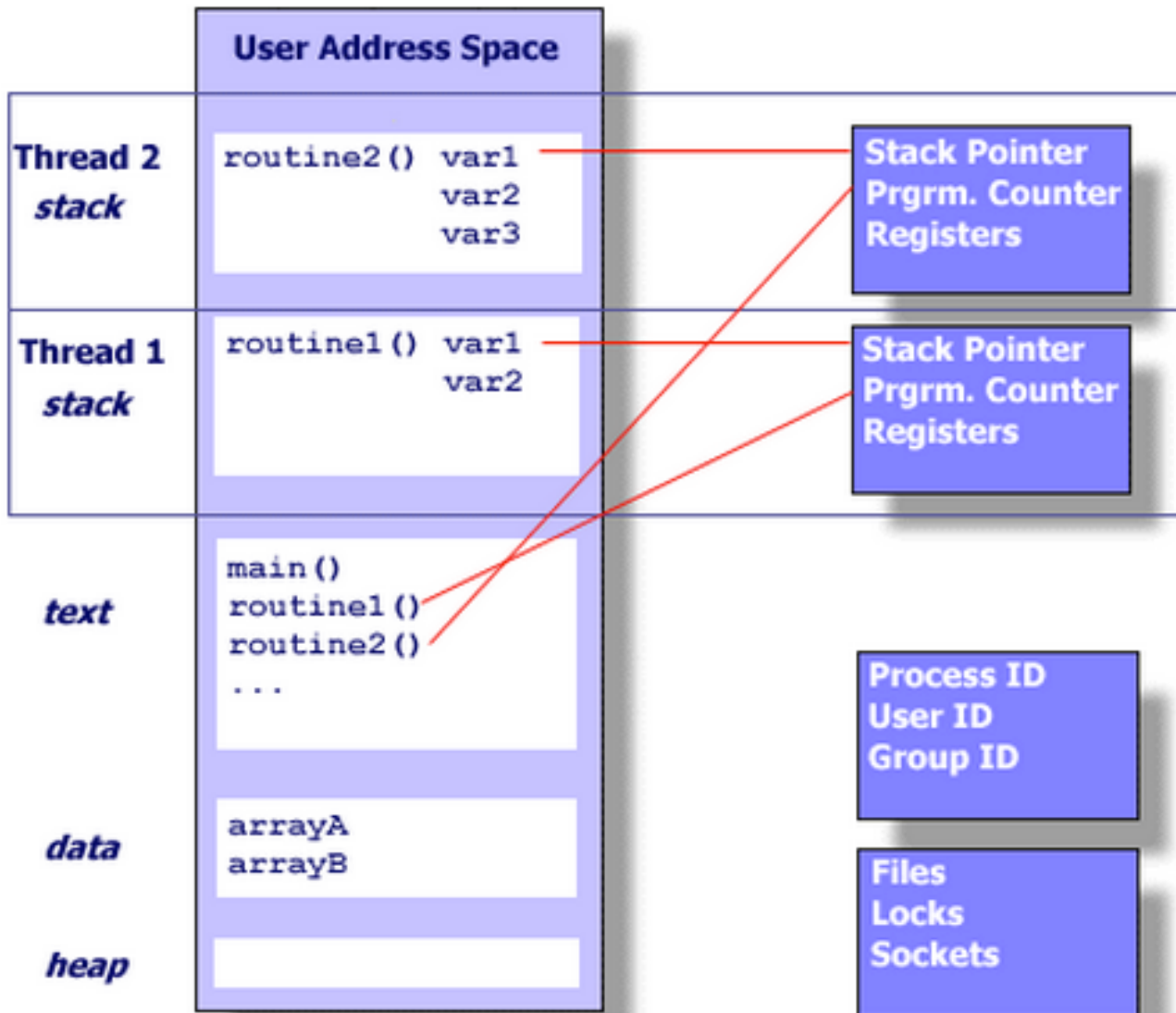

Stack pointer
Registers
Scheduling properties
(such as policy or
priority)
Set of pending and
blocked signals
Thread specific data

Thread

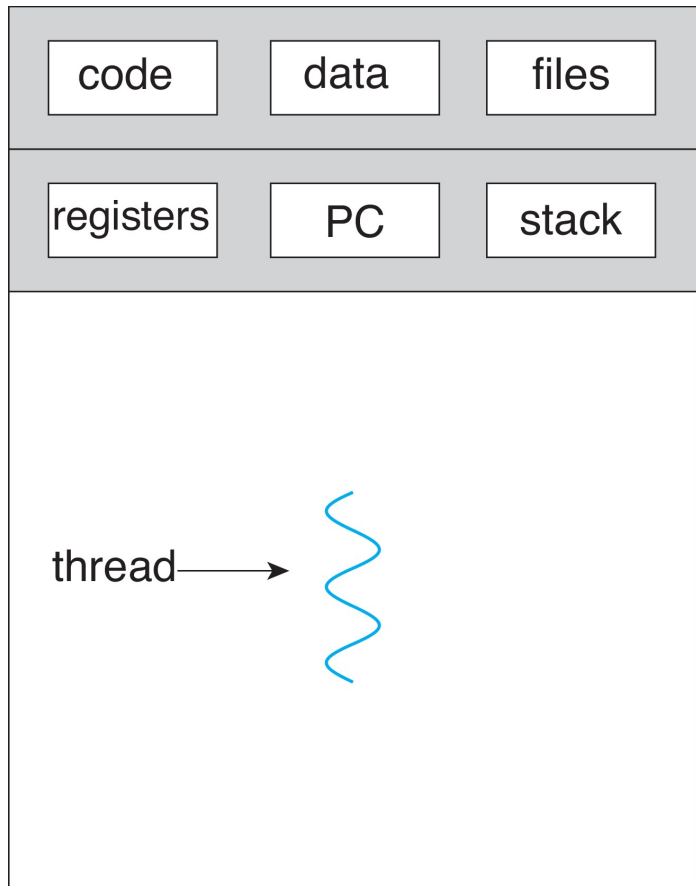

single-threaded process

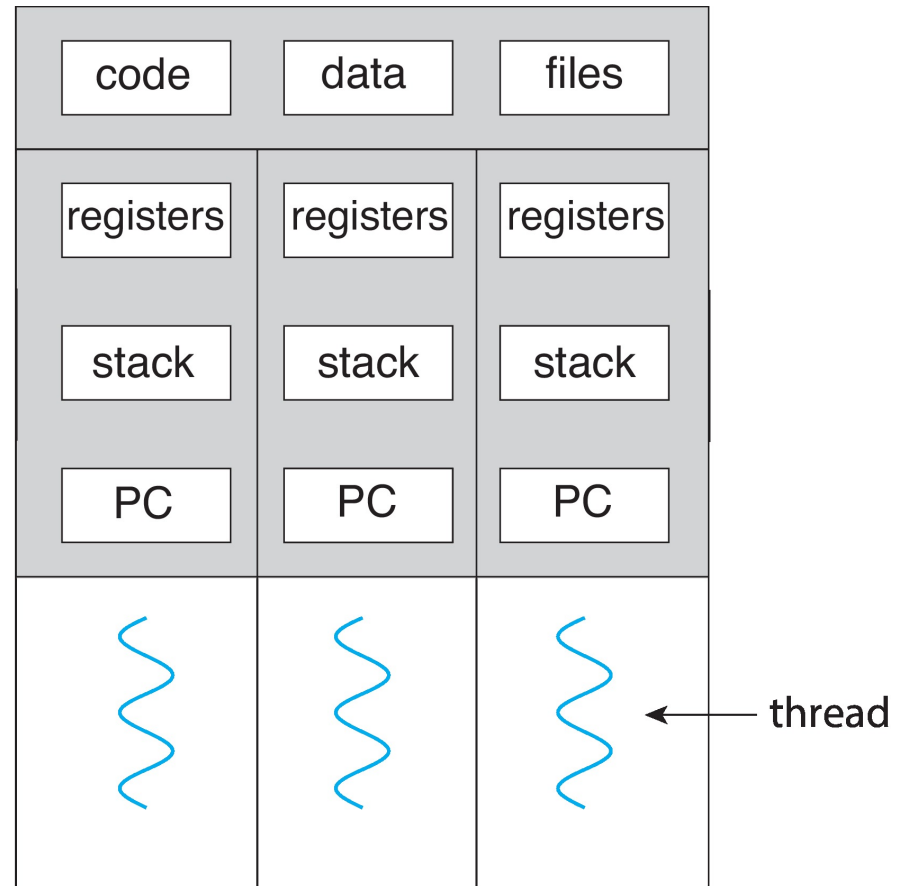

multithreaded process

Shared Memory Model

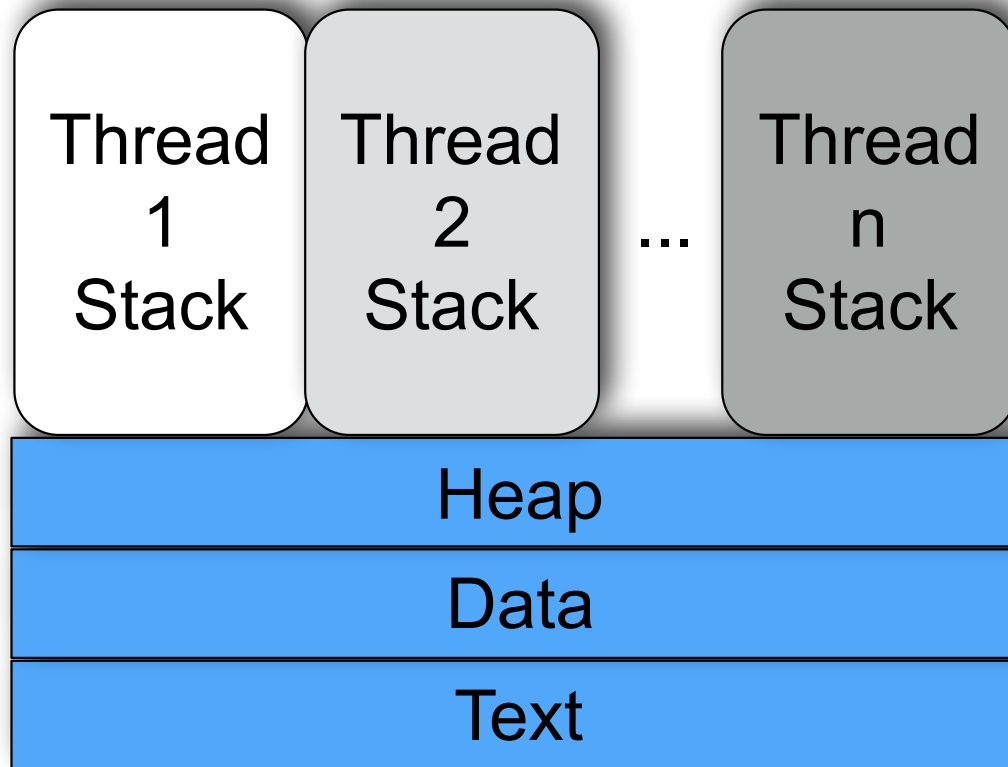

- All threads have access to the same global, shared memory
- Threads also have their own private data (how?)
- Programmers are responsible for protecting globally shared data

Thread Safety

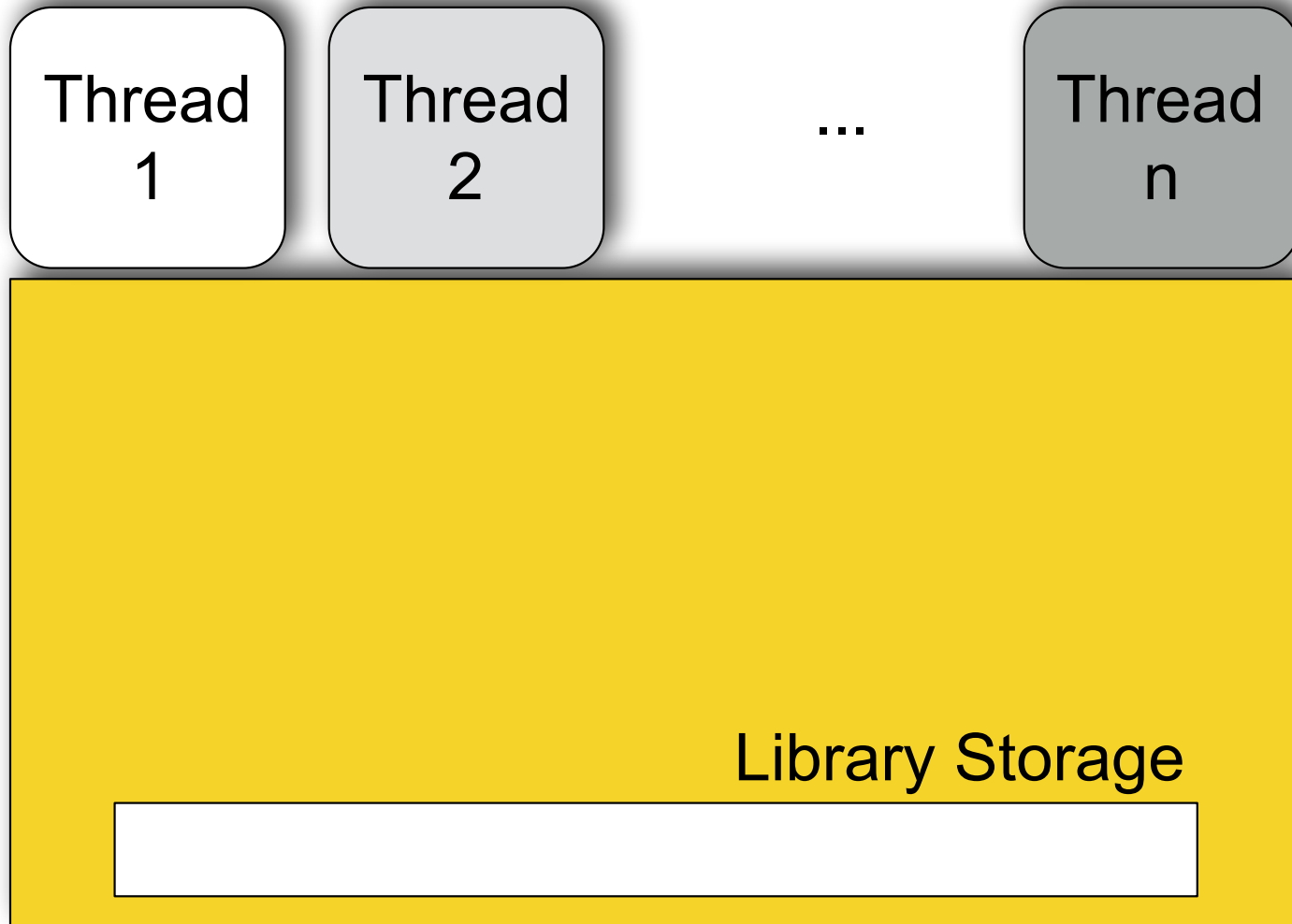

Thread Safety

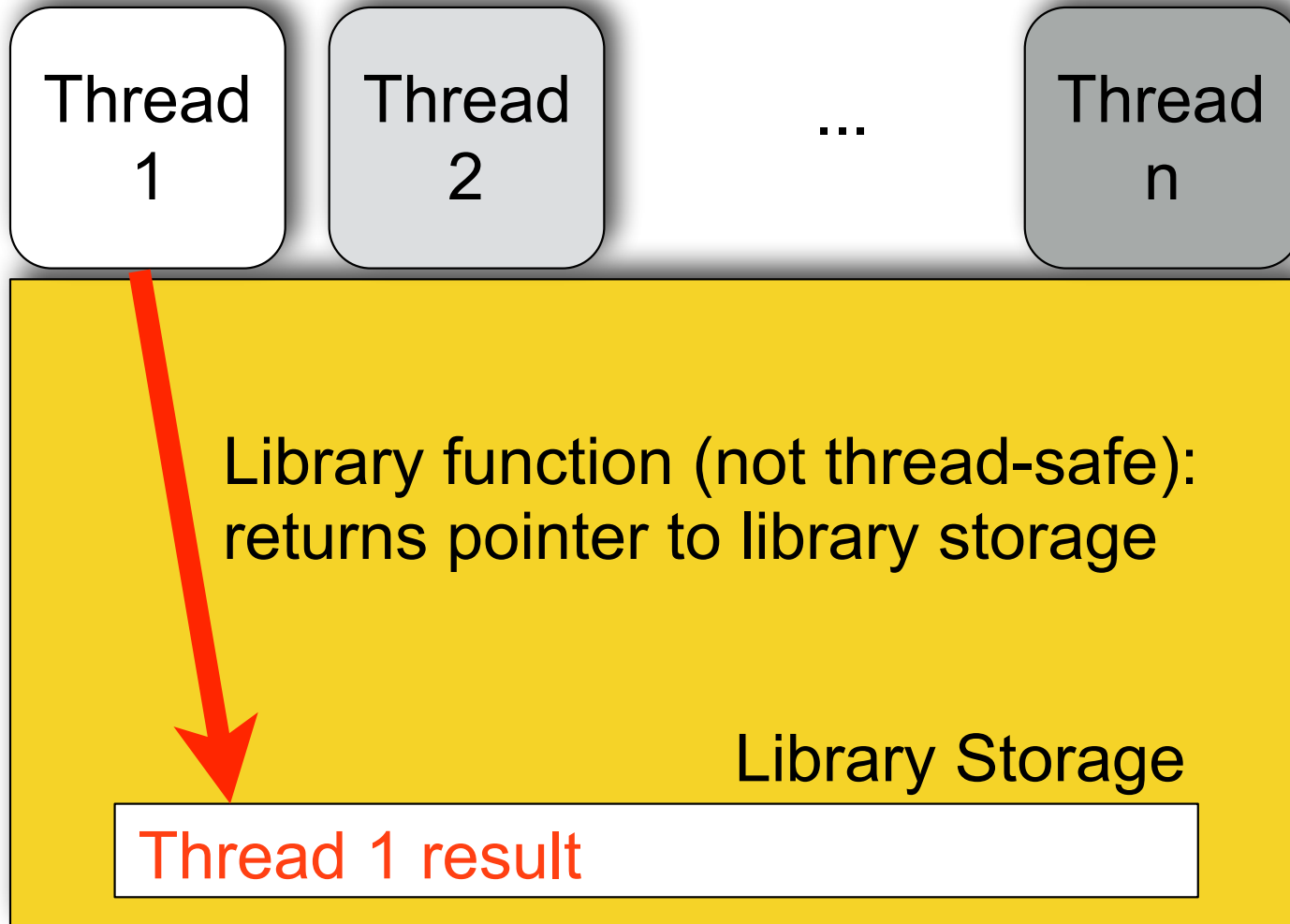

Thread Safety

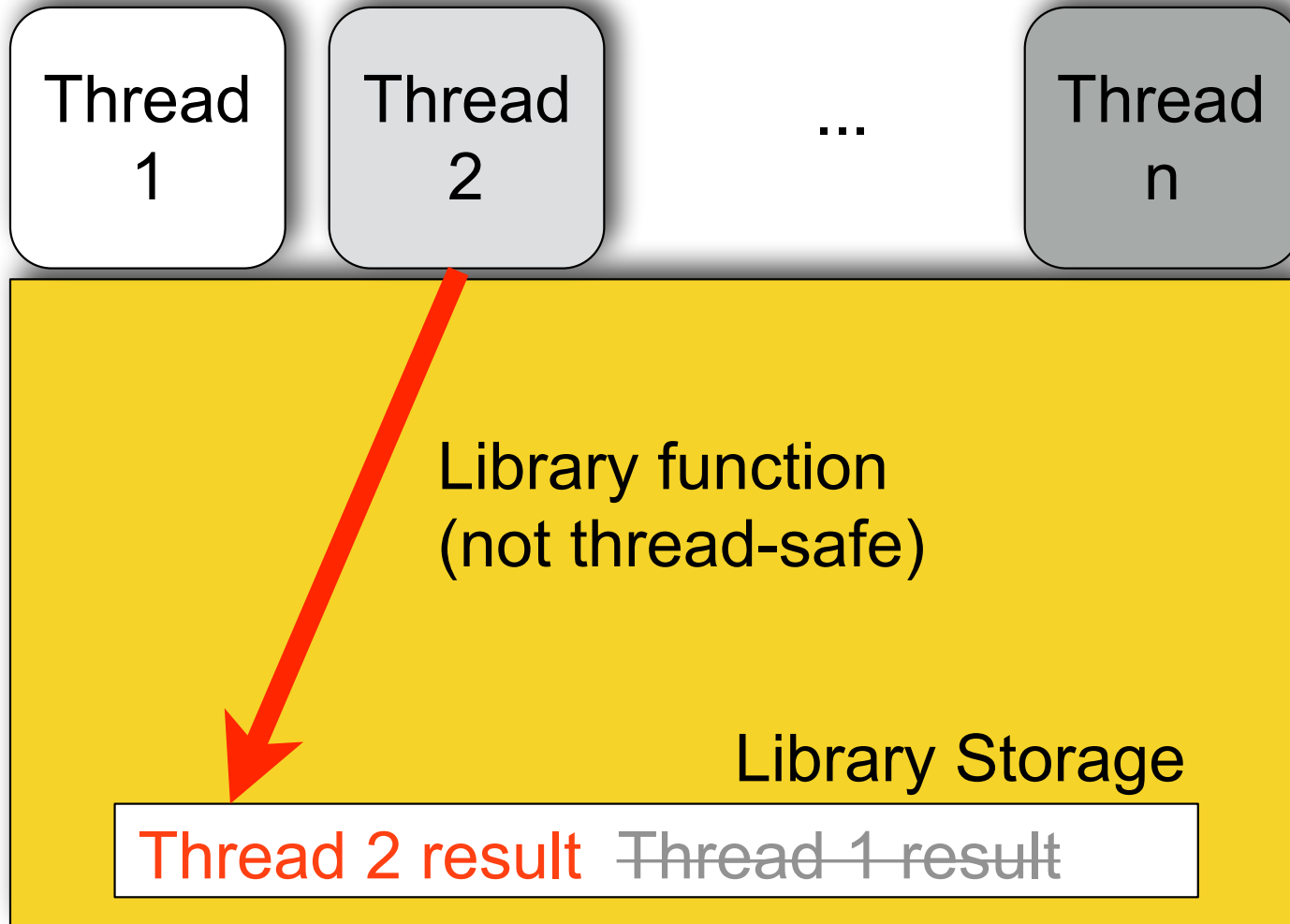

Thread Safety

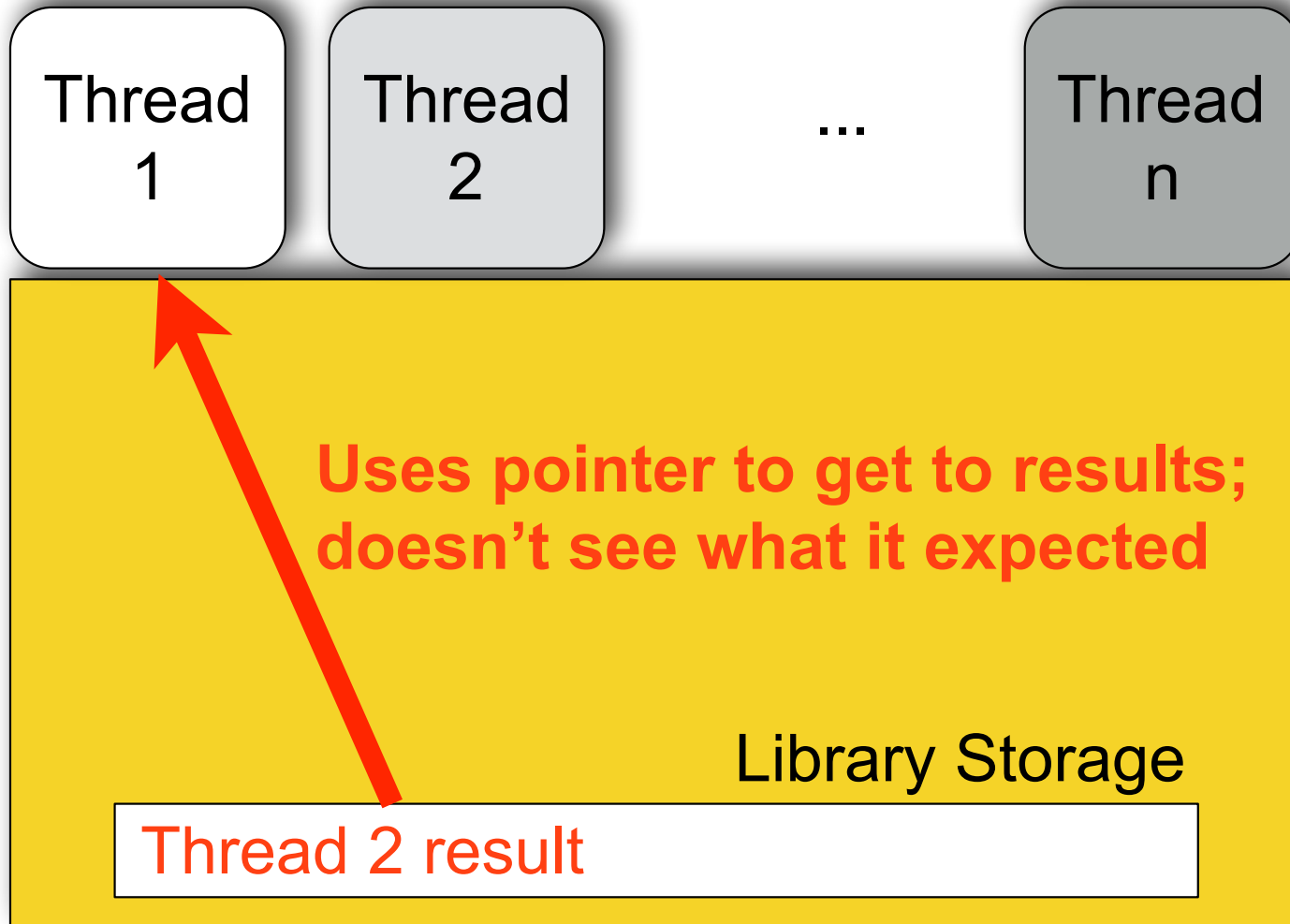

Thinking about Performance

Speedup

If you care about performance, your speed up needs to be bigger than 1. (If it's not, you have a problem.) But you need to be **honest!**

$$\text{speedup} = \frac{\text{time of the best sequential solution}}{\text{time of the parallel solution}}$$

Amdhal's Law

$$\text{speedup} \leq \frac{1}{S + \frac{(1-S)}{N}}$$

S = portion that must execute serially

$(1-S)$ = portion that can be parallelized

N = number of cores

AMDAHL'S LAW

SPEED UP BOUND

| SERIAL (SEC) | PARALLEL (SEC) |
|--------------|----------------|
| 0.001 | 0.999 |
| 0.005 | 0.995 |
| 0.01 | 0.99 |
| 0.05 | 0.95 |
| 0.1 | 0.9 |
| 0.5 | 0.5 |
| | |
| | |
| | |
| | |

| CORES | SPEEDUP BOUND |
|-------|---------------|
| 1 | 1.000 |
| 2 | 1.998 |
| 4 | 3.988 |
| 8 | 7.944 |
| 16 | 15.764 |
| 32 | 31.038 |
| 64 | 60.207 |
| 128 | 113.576 |
| 256 | 203.984 |
| 512 | 338.848 |

| CORES | SPEEDUP BOUND |
|-------|---------------|
| 1 | 1.000 |
| 2 | 1.990 |
| 4 | 3.941 |
| 8 | 7.729 |
| 16 | 14.884 |
| 32 | 27.706 |
| 64 | 48.669 |
| 128 | 78.287 |
| 256 | 112.527 |
| 512 | 144.023 |

| CORES | SPEEDUP BOUND |
|-------|---------------|
| 1 | 1.000 |
| 2 | 1.980 |
| 4 | 3.883 |
| 8 | 7.477 |
| 16 | 13.913 |
| 32 | 24.427 |
| 64 | 39.264 |
| 128 | 56.388 |
| 256 | 72.113 |
| 512 | 83.797 |

| CORES | SPEEDUP BOUND |
|-------|---------------|
| 1 | 1.000 |
| 2 | 1.905 |
| 4 | 3.478 |
| 8 | 5.926 |
| 16 | 9.143 |
| 32 | 12.549 |
| 64 | 15.422 |
| 128 | 17.415 |
| 256 | 18.618 |
| 512 | 19.284 |

| CORES | LINEAR SPEEDUP |
|-------|----------------|
| 1 | 1.000 |
| 2 | 2.000 |
| 4 | 4.000 |
| 8 | 8.000 |
| 16 | 16.000 |
| 32 | 32.000 |
| 64 | 64.000 |
| 128 | 128.000 |
| 256 | 256.000 |
| 512 | 512.000 |

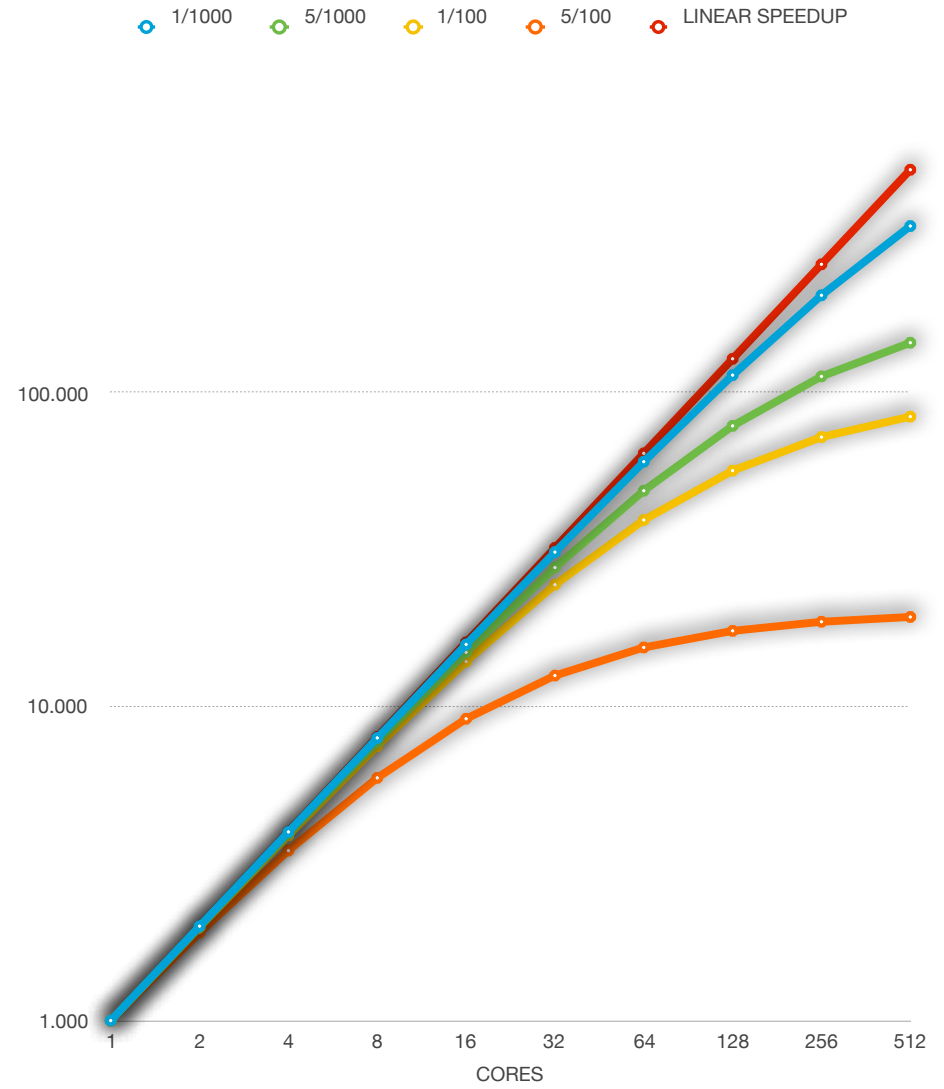

Challenges in Parallel Programming

- Identifying “parallelizable” tasks
- Load balance
- Data decomposition
- Data dependency
- Testing and debugging

Multithreading Models

User threads

Managed by a library without kernel support;
runs at user level

Kernel threads

Managed directly by the operating system

Many-To-One Model

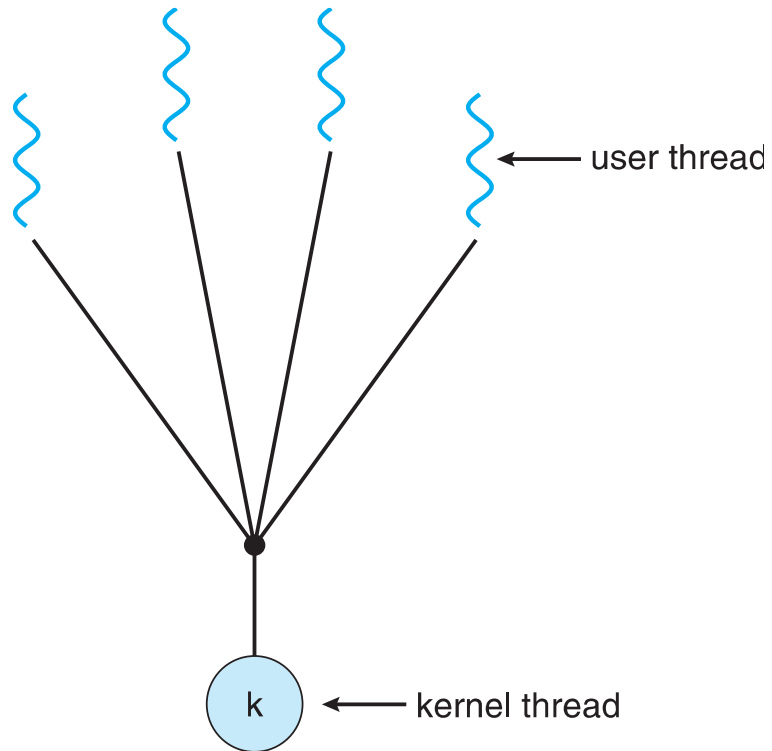

Disadvantages

Advantages

One-To-One Model

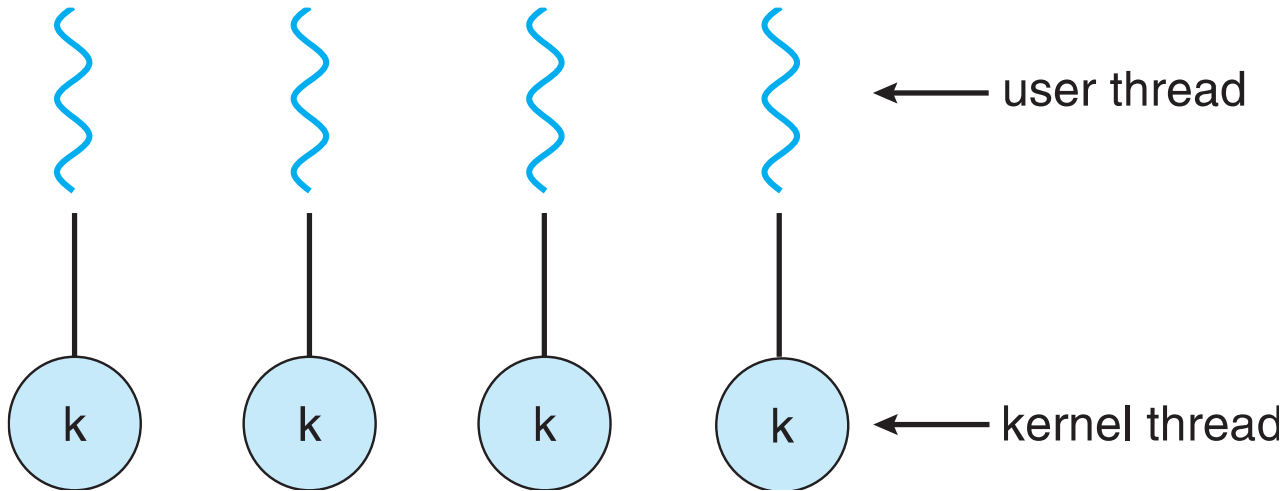

Disadvantages

Advantages

Many-To-Many Model

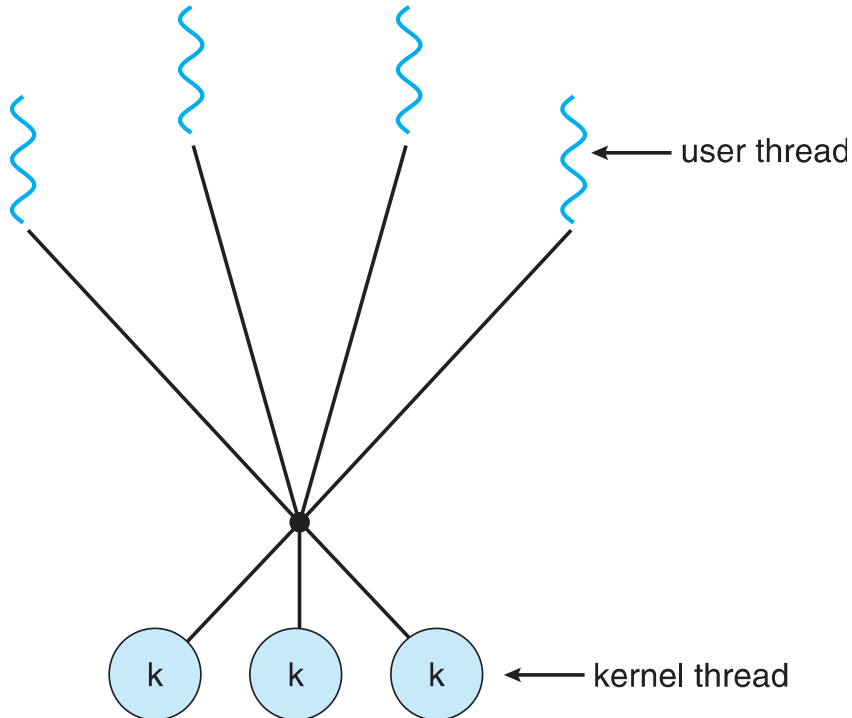

Disadvantages

Advantages

What are **thread pools**?

Anything good or bad?

A Typical Application

Multithreaded Server Architecture

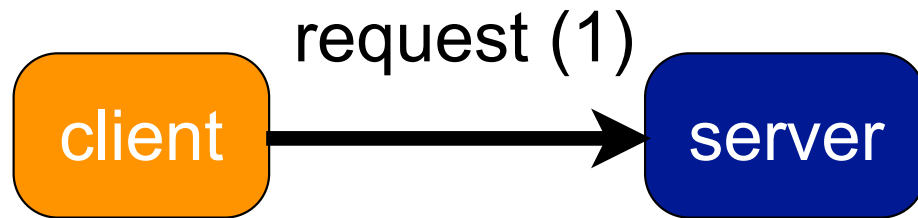

Multithreaded Server Architecture

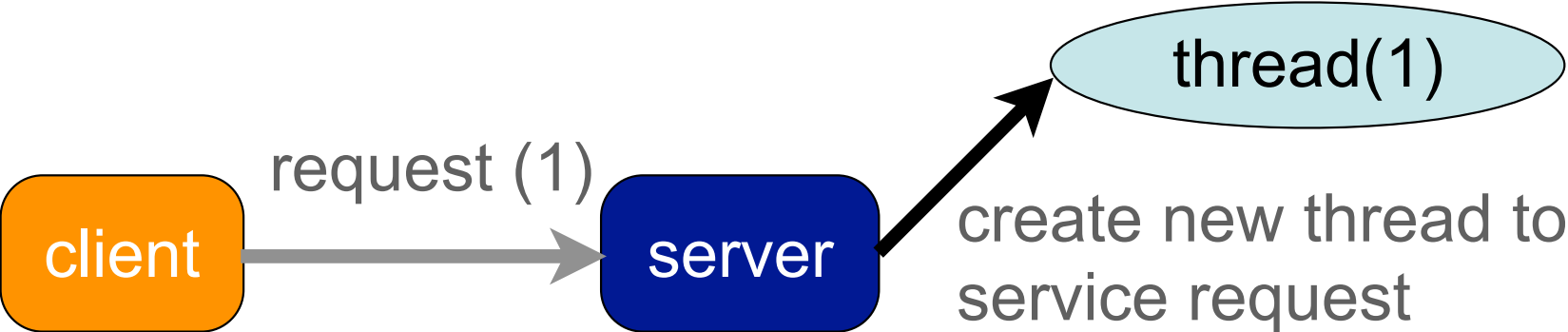

Multithreaded Server Architecture

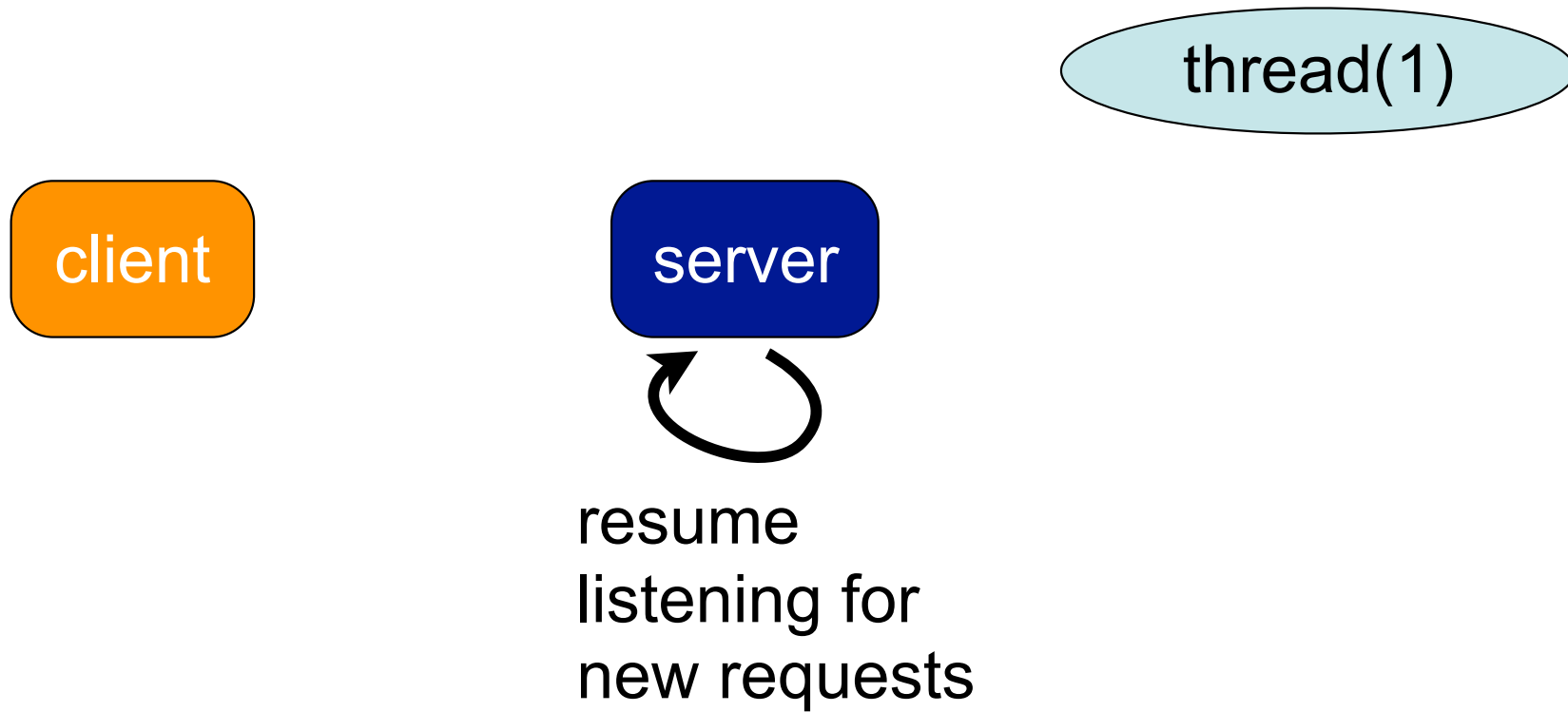

Multithreaded Server Architecture

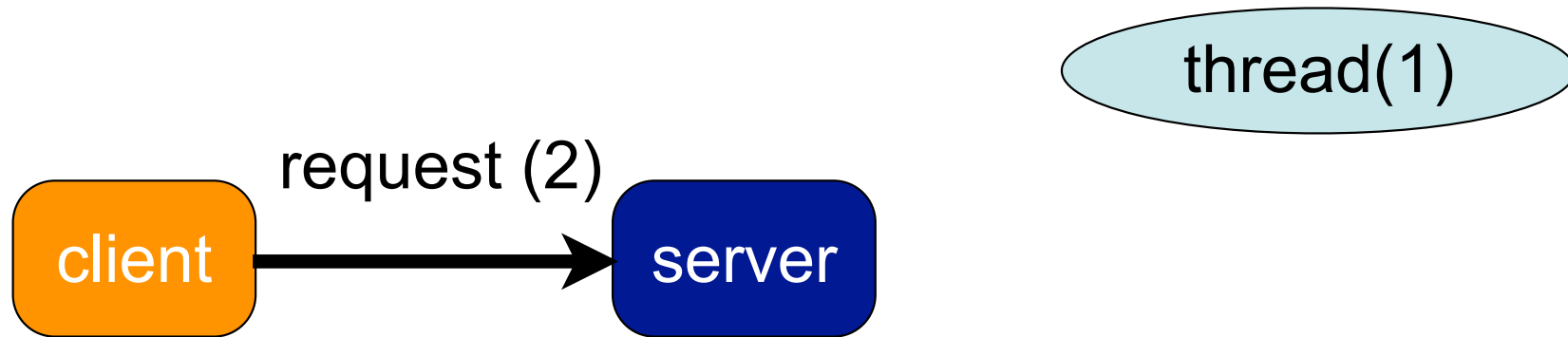

Multithreaded Server Architecture

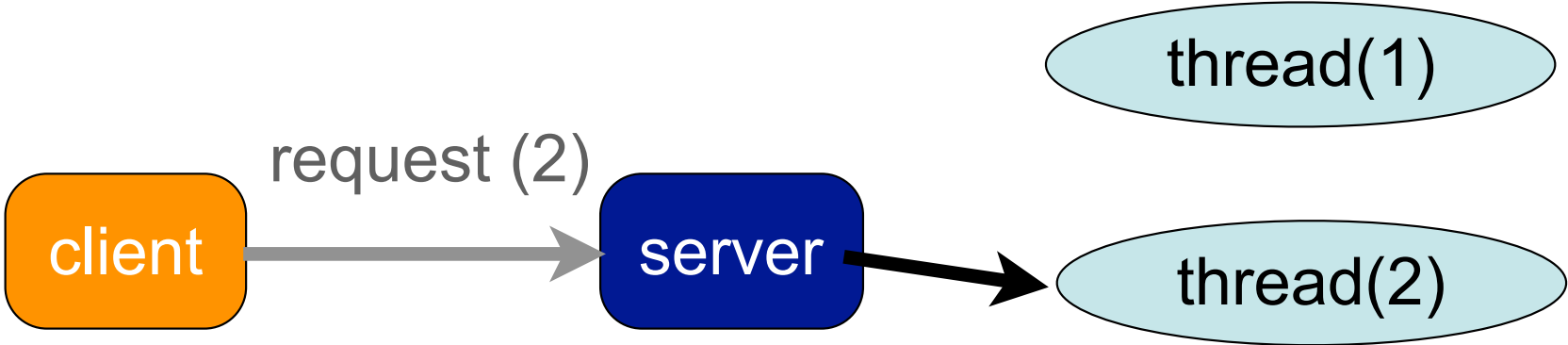

create new thread to service request

Multithreaded Server Architecture

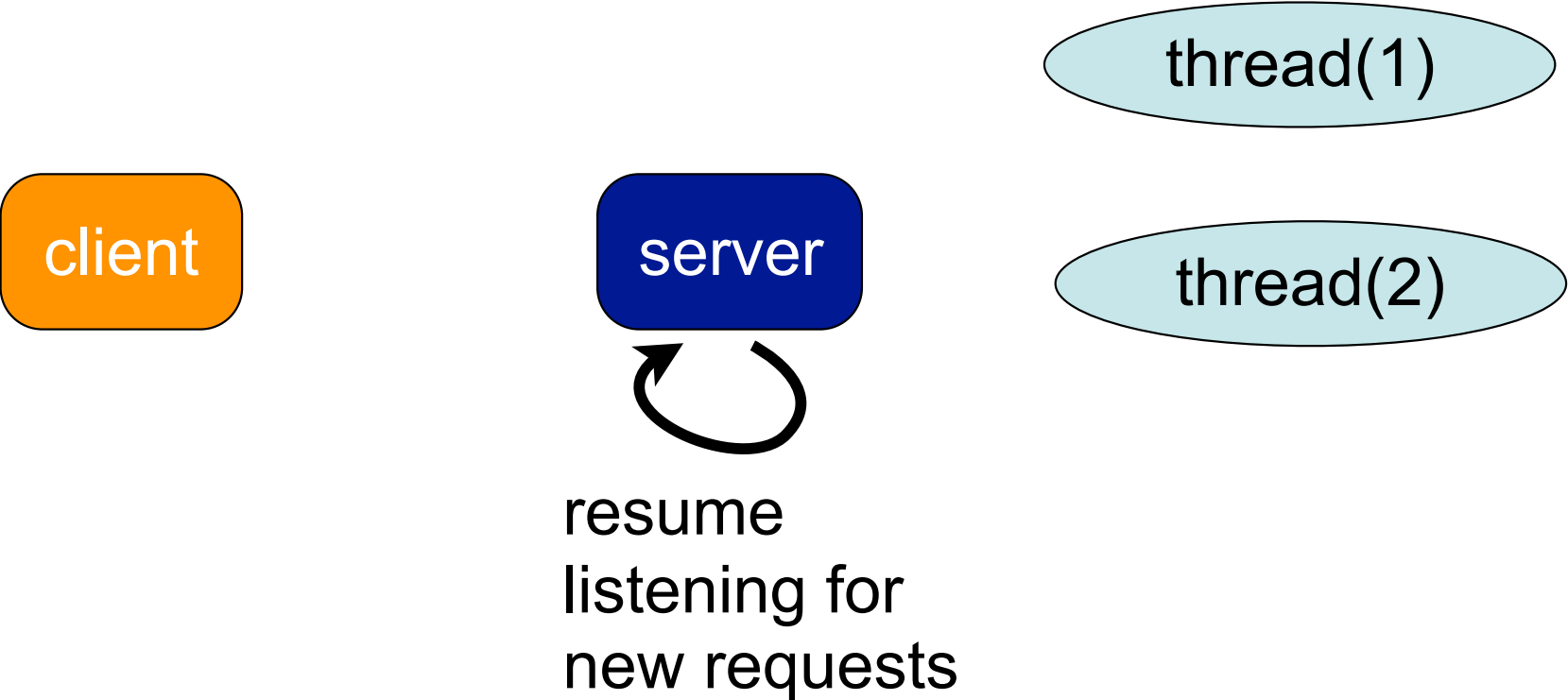

BACK
TO

BACK
TO

**Inter process
communication**

Inter process communication

- file
- pipe
- shared memory
- message passing
- ...

Processes on the
same machine

- remote
procedure call
- message passing
- sockets
- ...

Processes on
different machines

Networking

Connectivity

Wish List:

- Interconnect machines.
- Maintain data *confidentiality*, data *integrity*, and system *accessibility*.
- Support growth by allowing more and more computers, or nodes, to join in (*scalability*).
- Support increases in geographical coverage.

Links

Each node needs one interface (NIC) for each link.

point-to-point



multiple-access

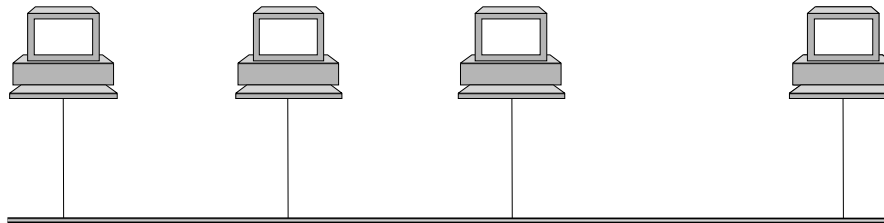

Geographical coverage and scalability are limited.

Switched Networks

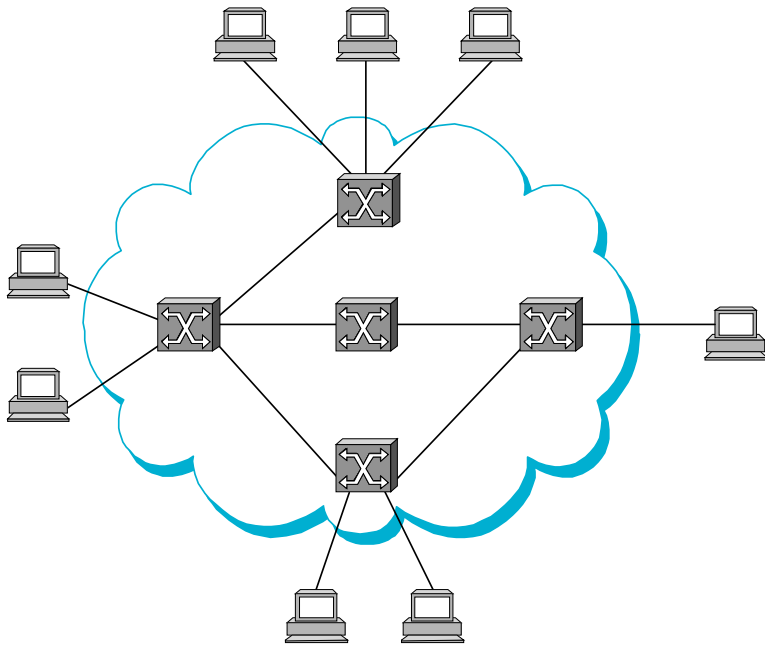

Circuit Switched

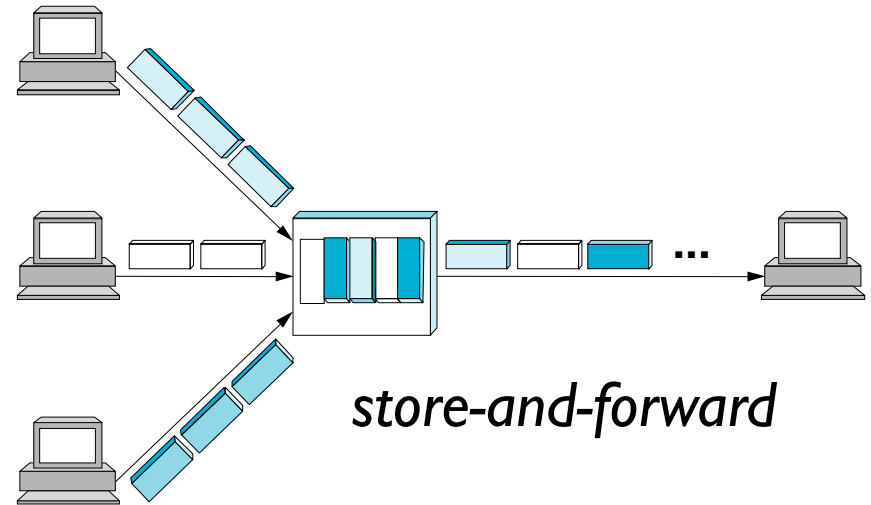

Packet Switched

Internetworking

To interconnect two or more networks, one needs a **gateway** or **router**.

Host-to-host connectivity is only possible if there's a uniform **addressing** scheme and a **routing** mechanism.

Messages can be sent to a single destination (**unicast**), to multiple destinations (**multicast**), or to all possible destinations (**broadcast**).

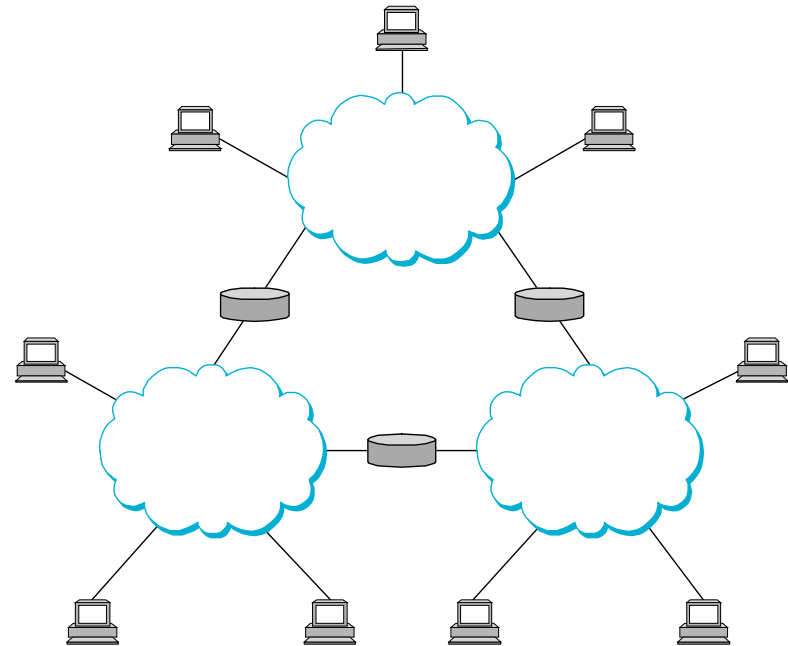

The ISO/OSI Reference Model

Source: Computer Networks, Andrew Tanenbaum

ISO: International Standards Organization

OSI: Open Systems Interconnection

The protocol *stack*:

The idea behind the model: Break up the design to make implementation simpler. Each layer has a well-defined function. Layers pass to one another only the information that is relevant at each level. Communication happens only between adjacent layers.

Application

Presentation

Session

Transport

Network

Data link

Physical

The Layers in the ISO/OSI RF Model

Physical: Transmit raw bits over the medium.

Data Link: Implements the abstraction of an error free medium (handle losses, duplication, errors, flow control).

Network: Routing.

Transport: Break up data into chunks, send them down the protocol stack, receive chunks, put them in the right order, pass them up.

Session: Establish connections between different users and different hosts.

Presentation: Handle syntax and semantics of the info, such as encoding, encrypting.

Application: Protocols commonly needed by applications (cddb, http, ftp, telnet, etc).

Communication Between Layers in Different Hosts

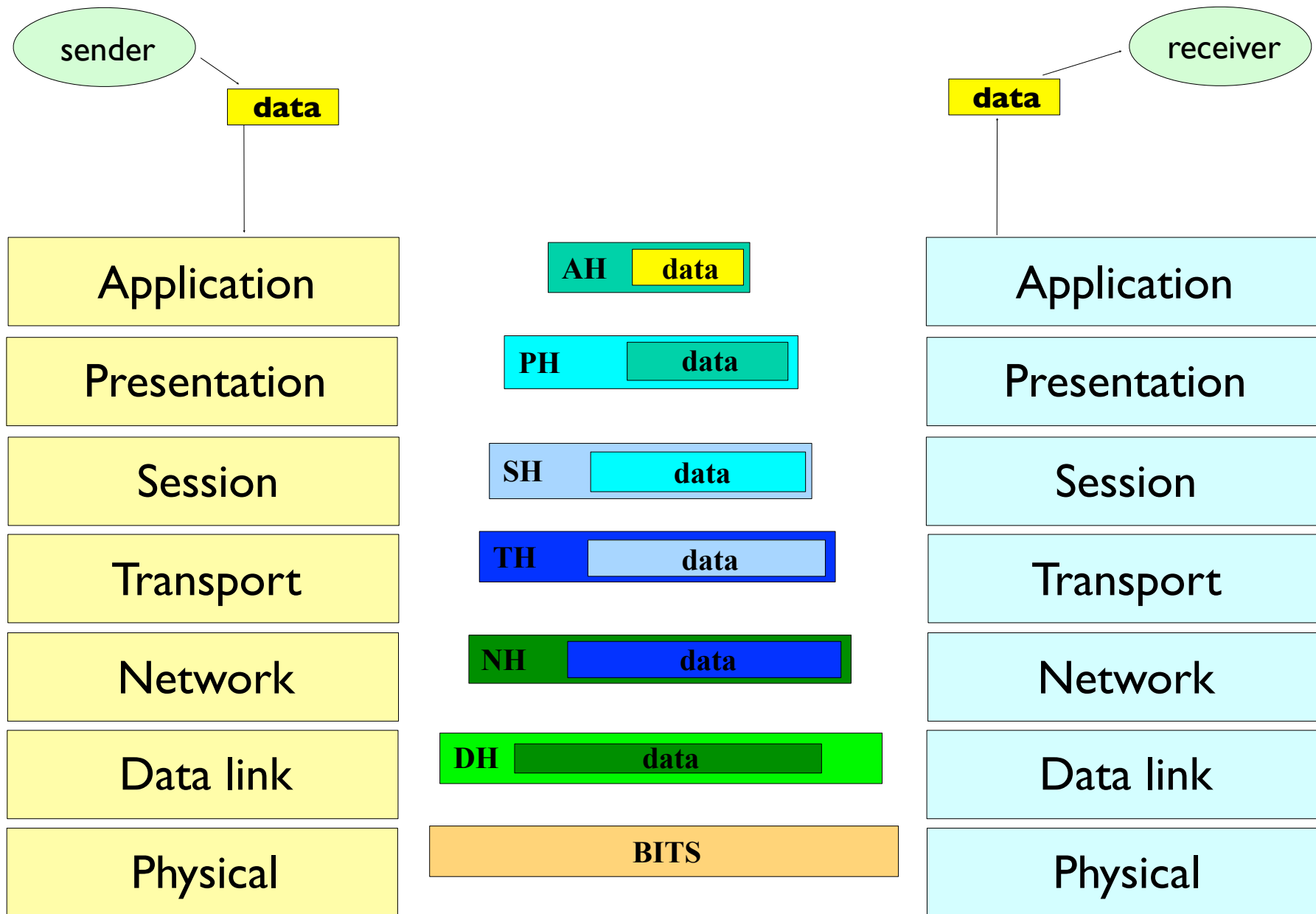

The Layers in the TCP/IP Protocol Suite

Source: The TCP/IP Protocol Suite, Behrouz A. Forouzan

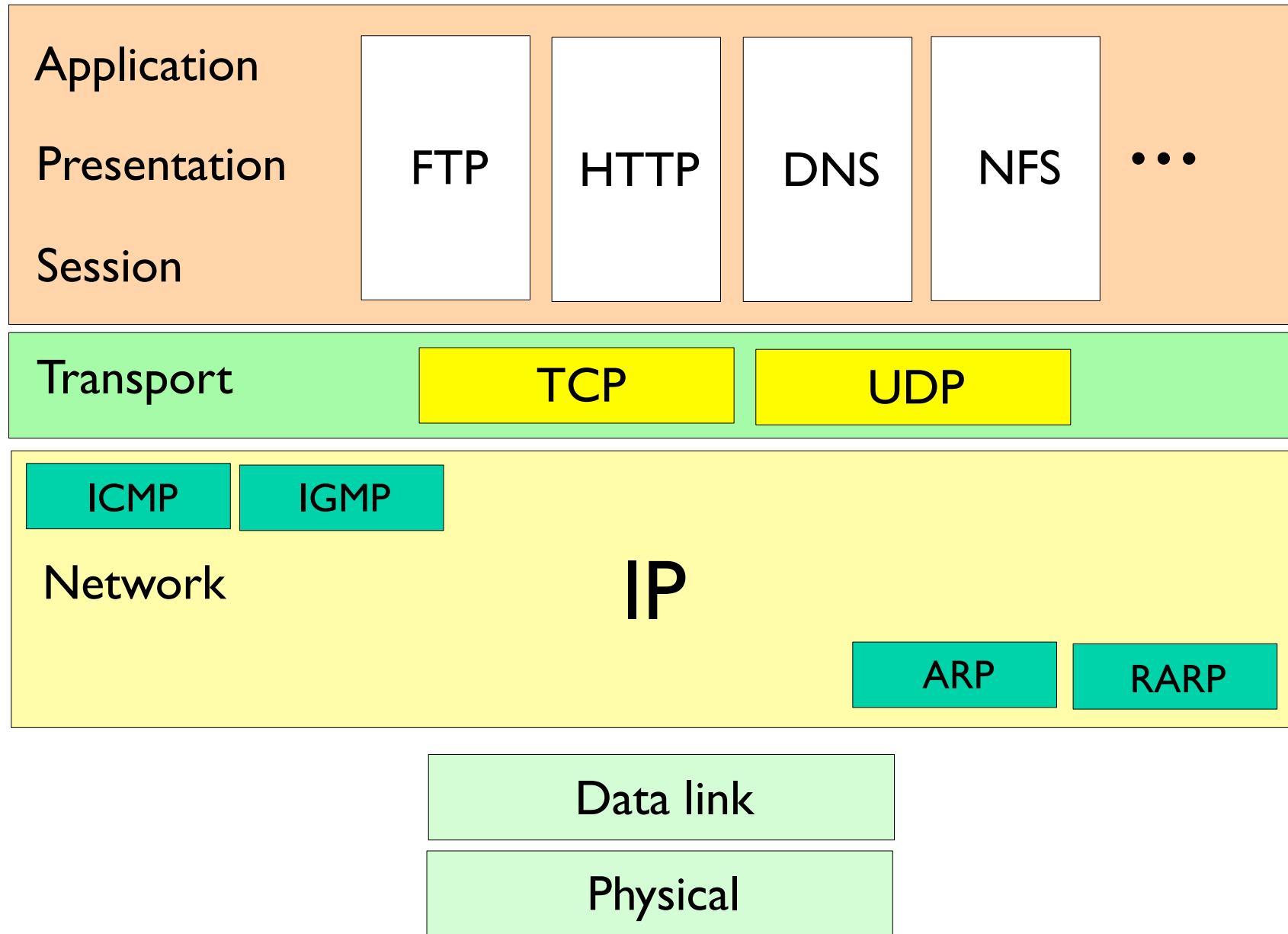

Socket Functions

